

SAFETY NOTICE

WARNING! POWER LINES CAN KILL YOU

DO NOT ERECT THIS ANTENNA NEAR ANY OVERHEAD WIRES, UNDER ANY CIRCUMSTANCES. READ AND FOLLOW THESE INSTRUCTIONS CAREFULLY

- 1) Do not erect this antenna near any overhead wires. Assume all such wires to be power lines and deadly.
- 2) Do not transport this antenna from an assembly location to the installation site if you must travel near or under overhead wires.
- 3) Request advice from your local power company if power wires are anywhere near the proposed location.
- 4) If the antenna falls, DO NOT try and stop it. Get out of the way.
- 5) If any part of the antenna should touch overhead wiring, DO NOT TOUCH IT OR ATTEMPT TO MOVE IT. Call the power company immediately for help.
- 6) In the event of an accident involving power wiring DO NOT TOUCH THE VICTIM DIRECTLY. Send someone for help.
- 7) Select a site which limits public access to the antenna. During operation the antenna has a high RF potential. If any possibility exists that people or pets could touch the antenna, place a wooden fence around it.
- 8) Choose a calm, dry day to erect the antenna.
- 9) Always enlist the aid of at least one competent person in erecting the antenna.
- 10) Do not use a ladder in the process of erecting your GAP Antenna. A ladder is not needed and could be dangerous.
- 11) Do not connect the coax until the antenna is firmly mounted.

7.0 GENERAL

The TITAN DX has been designed to operate on the 8 bands specified. Operation outside the specified bands may damage the antenna.

Use of an antenna tuner is not required nor recommended. Tuners will not improve the performance of the antenna, although they may permit a solid state transmitter to put out more power.

Operation of the antenna using a tuner on any frequency where the VSWR exceeds 2:1 may damage the antenna. Use when VSWR is less than 2:1 is acceptable.

7.1 MALFUNCTION

A) If the antenna fails to resonate on the 75/80 meter band the CAP unit plugged on at the top of the antenna may not be making proper contact or was inadvertently shorted when the screw was inserted.

B) If all your standing waves are high, double check the PL259 connector at the base of the antenna and make sure it is open from center pin to shield.

C) If only a couple of bands are high eliminate the following possibilities;

- 1) Bad coaxial feedline. If the coax has been in use for some time, it may be contaminated. Place a 50 ohm dummy load at the far end of your feedline, in place of the antenna. Any indication of varying VSWR or a standing wave greater than 1:1 suggests defective coax.
- 2) Mutual coupling with nearby vertical metal objects may detune the TITAN. Check to see if any of the items suggested in section 1.2 & 1.3 apply.
- 3) Transceivers with built in SWR bridges may not correctly indicate when their power reduction circuits take over. Retest with a separate VSWR meter.
- 4) The transceiver or transmitter may be emitting a spurious signal in addition to the desired signal. Retest using the lowest possible power level. If possible try another rig.

If you are unable to solve the problem, contact the factory for assistance. Please have section 6.2 filled in and handy when you call. We do not charge for assistance and our phone number is (561) 571-9922.

READ THE SAFETY NOTICE ON PAGE 1 BEFORE CONTINUING

CHAPTER 1: **SITE CONSIDERATIONS**

1.0 **General**

Ideally, it is best to locate the TITAN in a clear area, away from wires, metal buildings, fences and trees. As a practical matter, many amateurs must compromise in locating their antennas. This section contains specific guidelines to assist in making those compromises.

1.1 **Site Safety**

- A) Reread the safety notice now. Stay away from power lines, they are life threatening.
- B) Choose a site that it is not easily accessible to people or pets.

CONTACT WITH THE ANTENNA IS DANGEROUS AND CAN BE FATAL.

The counterpoise rods and the rest of the TITAN may be at high RF potential during operation. If it is not possible to site the TITAN to prevent access, then it should be placed high enough such that people cannot reach it or it should be surrounded by a fence.

1.2 **Nearby Wires and Antennas**

- A) In general, any vertical antenna can exhibit mutual coupling with any other vertical metal structure or wire if placed within a few wavelengths or the structure approaches resonance at the operating frequency.
- B) Try to avoid metal objects which may be within 30' of the proposed GAP installation site. These may include wires, towers, down spouts, screened porches, feedline from other amateur antennas or TV antennas, metal pipes on your property or adjoining properties. Naturally, if these metal objects are short you can get closer than 30'.
- C) Nearby horizontal wires or structures may affect the performance of a vertical antenna, but they are not as likely to, as a vertical structure is.

1.3 **Buildings**

- A) It is best to locate the antenna as far from the home as possible, to minimize interaction with house wiring, and RFI to consumer electronics.
- B) Metal walled or roofed buildings can affect antenna operation. If you have no choice, your GAP should be located at a corner of the building, rather than broadside. In any case, the TITAN should be tested first away from the building. See Section 6.0.
- C) Stucco buildings may have metal mesh in their walls and should be viewed as a metal structures, until proven otherwise.
- D) Mobile homes or RV's are a special case, which involve individual experimentation. Test the antenna on the ground before attempting installation near or on the RV. Mounting above the roof line is preferred.

1.4 **Guying**

The TITAN is designed to withstand substantial winds unguyed. Guys are a form of insurance, however, which we recommend. Four nonconductive guy ropes should be fastened above the center insulator. Use a stainless clamp or optional guy clamp available from GAP. Leave some slack to allow for temperature changes. Guys should be used for roof mounting. Do not rely on a chimney mount or tripod to support the TITAN, even moderate winds can produce enough force to damage the mount or the chimney.

PG5

CHAPTER 3: **ASSEMBLY**

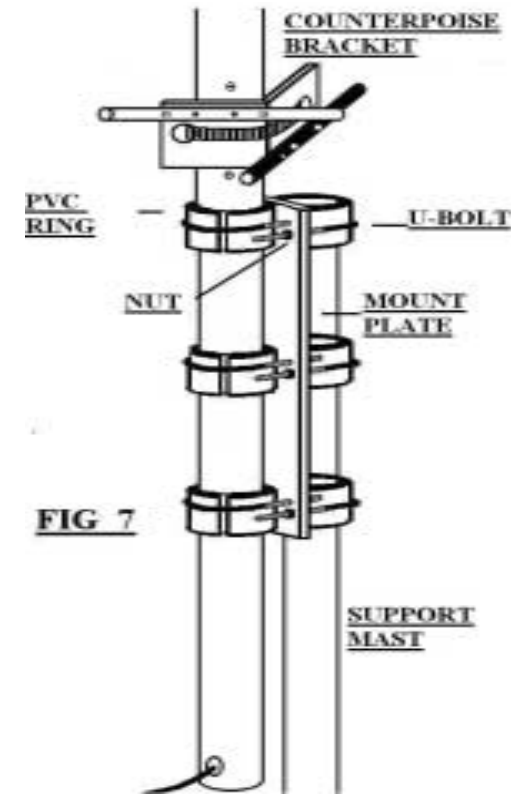

FIGURE 7

6.0 PRETEST PROCEDURE

It is always best to test the TITAN at ground level before elevating it. Pretesting is not difficult and may save time and effort in the total process. This is particularly true if the antenna is to be significantly elevated.

- A) Locate an open space.
- B) Obtain an 1 1/4" pipe 5' long.
- C) Attach this pipe to the TITAN see section 5.4.
- D) Obtain 3 lengths of rope 25-30' long.
Attach ropes just above the GAP center insulator.
- F) Dig a small hole or insert a small diameter tube or large screwdriver in the ground,
- G) With help raise the antenna until it is vertical.
- H) Place your 5' pipe in the hole or over the screwdriver or tube, this will keep the base in place.
- I) Secure the temporary guy ropes.
- J) Complete the hoop assembly see section 5.3. For this test it is not necessary to put screws into the Counterpoise rods.

3.0 General

The assembly of the GAP TITAN requires no special tools and a nut driver has been supplied for your convenience. Plastic stand-offs that support the tuner rods are attached to the aluminum mast at their approximate proper positions to simplify assembly. Do not remove these at this time. Before starting assembly, check the various parts in the shipping container against the pictorial parts list in figure 2 to establish all parts are present. Next review Figure 1 which depicts an assembled TITAN. As you proceed to assemble your TITAN, use this diagram.

NOTE: That in the assembly instructions, when a single hole is identified on a tuner rod it is thru drilled. Thru drilled holes provide you with a backup should you accidentally strip a hole by over tightening.

We found that telling you to insert a screw and washer gets repetitive, therefore whenever a screw is called for include a washer as well. When attaching jumpers and transitions, the washer should be placed between the ring terminal and the tube. Not between the screw head and ring terminal.

When we refer to the "GAP" we are referencing the center insulator with the yellow band.

3.1 Space Required

To get started with the assembly, you will need a flat space approximately 30' in length. A driveway or patio surface is ideal. The key to an easy assembly is room to move, a surface which allows you to find the screws you drop and careful attention to the directions. Extra crews have been provided because we know how lawns like to eat screws.

3.2 Mast Assembly

Standoffs are positioned on the various mast sections at their approximate final positions. Do not loosen the clamps.

A) Locate the Main Section. Place the Main Section on a flat surface. Stretch out the coax that protrudes from each end. **NOTE** The coax that goes to the top of the antenna has a yellow ring terminal.

B) Locate the Top Section. Place the end without the notch over the coax cable with the yellow terminal.

C) Slide the Top Section into the Main Section. Gently push the Top Section into the Main Section beyond the matching holes, until the yellow terminal and spade connectors are exposed.

D) Plug the CAP unit onto the spade connectors found on the coaxial cable. **Make sure the male spades on the CAP unit align with the female spade terminals on the coax.**

E) Pull the Top Section back out and align it's four screw holes with the four holes in the Main Mast Section. Insert 4 screws. Snug all screws first before tightening one particular screw.

NOTE This procedure should be repeated wherever multiple screws are inserted. Snug first then tighten

F) Place the yellow ring terminal at the top of the antenna through the slot and over the nearby drill hole. Insert a screw and tighten securely. **WARNING:** Make sure the CAP unit is pushed down below the screw, so it does not crack the CAP unit when you insert it.

G) Locate the black dust cover and place it over the Top Section.

- E) Locate the wire extension with the two ring terminals
- F) Take the ring terminal from the Counterpoise Hoop wire and one terminal from the wire extension. Place both terminals over the drill hole at the end of the 80" counterpoise rod that has the yellow end cap and is attached to the aluminum tube on the Counterpoise bracket. see figure 6. Insert a screw attaching these terminals to the Counterpoise rod.
- G) Circle the ends of the Counterpoise rods with the Counterpoise Hoop placing an End Cap on each Counterpoise rod as you circle.
- H) Find the Dacron cord with the ring terminal. Feed the end of the Counterpoise wire thru the split bolt, the ring terminal on the Dacron cord and back through the split bolt. The distance between the split bolt and the ring terminal on the Dacron should be about 2" or running the wire through the split bolt, the ring terminal on the Dacron and back through the split bolt creates, roughly a 2" loop.
- I) Thread the Dacron cord thru the vacant ring terminal of the wire extension. Pull the cord until the Counterpoise Hoop has no slack in it but, do not over tension the hoop. For starters your Dacron should be about 12". If necessary slide some of the hoop wire through the split to either create more length or take up slack. Tie a temporary knot in the Dacron cord to the ring terminal on the wire extension.

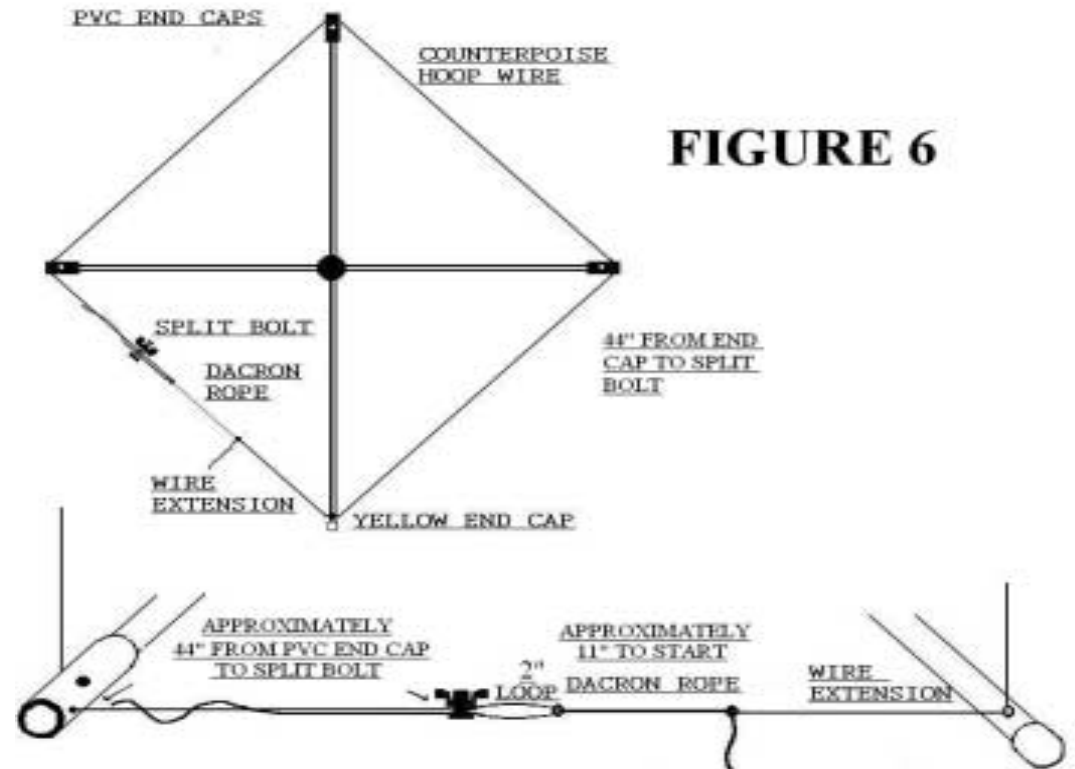

FIGURE 6

- A) Locate the two short standoffs on the Main Section. Slide the 51" Top tuner rod thru these standoffs so the screw holes are towards the GAP. Loosen and adjust the standoffs so the tuner rod is parallel to the mast, now tighten the clamps.
- B) Locate the drill hole 10" from the end of this tuner rod. Position this hole between the two standoffs and insert a screw and tighten. This is a stop screw
- C) Slide the tuner rod toward the GAP. Locate a black jumper. Remove the screw holding the lower GAP lead, see fig. 3. Place the black jumper under the screw with the GAP lead, reinsert and tighten.
- D) Attach the other end of the jumper to the hole at the end of the Top tuner rod with a screw and tighten.
- E) Locate the four standoffs on the Mid section just below the GAP. Loosen their clamp. Form these four into a cross, perpendicular and immediately below the GAP. Tighten the clamp securely.
- F) Locate the four standoff assembly at the top of the Lower Section. Form these four into a cross perpendicular to the mast. Tighten the clamp **lightly**. Now locate the longest standoff on the upper cross assembly. Rotate the lower cross assembly until it's longest standoff is in line with the one on the upper unit. Tighten the clamp.
- G) Take the four 102" Mid tuner rods and insert a screw in the hole 10" from the end of each rod and tighten. This a stop screw.
- H) Slide a 102" rod thru each standoff in the top cross, starting with the end opposite the screw just inserted and then into the bottom standoffs. Each rod should be parallel to the Main mast. You may have to adjust the lower cross unit to achieve parallel rods. Each rod should stop at the stop screw.
- I) There are four yellow transition wires at the GAP, one longer than the other three. Attach one to each Mid tuner rod with a screw and tighten. The longest wire attaches to the tuner rod on the longer standoff. All wires should not be taut. If you find a wire is taut it may be necessary to rotate the two cross units to relieve any tension on the transition wires.
- J) Locate the extension rod with the attached slotted extender. Locate the Mid tuner on the longer standoffs. Slide the slotted extender over the bottom end of this 102" rod until it butts against the extension. Rotate the extender until the hole in the Mid tuner rod lines up with the slot in the extender. Insert a screw into this hole and slot and tighten. See figure 4.
- K) Locate the remaining extender and place it over the Mid tuner rod opposite the tuner rod just installed. Align the slot in the extender with the hole on the tuner rod and secure as in J. It should extend about 4.5 inches and has no additional rod inserted into it.
- L) Loosen the clamp on the short pair of standoffs on the Lower section. Rotate this pair until they line up with the Mid tuner rods without the extenders.
- M) Take the last two short standoffs on the Lower section, loosen each clamp and orient one of these standoffs so it is in line with one from the pair above it. Orient the other so it is in line with the remaining standoff of the pair. Tighten the clamps.

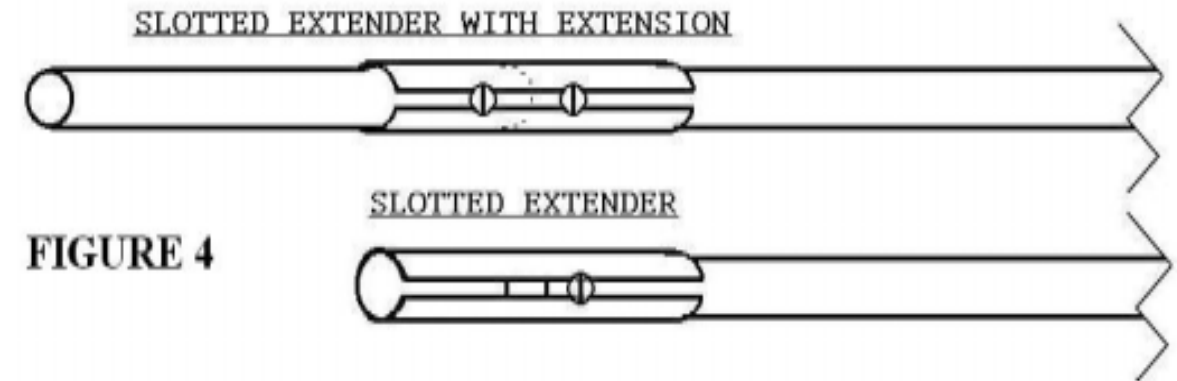

FIGURE 4

- N) Slide the shortest Lower tuner rod through the closest spaced standoffs, with the drill hole closest to the GAP. Locate a black jumper and attach one end to the top of the short tuner rod with a screw and tighten.
- O) Slide the longer lower tuner rod thru the remaining short standoffs, again, so the screw hole is closest to the GAP. Take the remaining black jumper and attach it to the top of this rod with a screw and tighten.
- P) Take the other ends of each black jumper and attach it to the Mid Tuner rod directly above with a screw and tighten. These jumpers should be loose. If they are taut you can raise or lower the position of the clamp on the short standoff pair to remove any tension. Proper positioning can be achieved by making sure the bottom of these two Mid tuner rods are in the same plane as the tops of your Lower tuner rods.

CHAPTER 5 : COUNTERPOISE AND HOOP ASSEMBLY

5.0 GENERAL

The Counterpoise and hoop assembly includes a Counterpoise support bracket, 4-80" rods, Counterpoise Hoop - a 35' length of copper wire with a ring terminal, a 4' length of Dacron with a ring terminal, 3 counterpoise End Caps and a 4' 9" fixed wire extension with 2 ring terminals.

5.1 Counterpoise Bracket Assembly see figure 5.

- A) Locate the Counterpoise bracket. It is partially assembled. Locate the 3/4" x 9" long PVC section with the 2 rivets inserted.
- B) Push a 11/4" screw thru one of the vacant holes in the aluminum bracket. Place one of the drill holes in the PVC tube over this screw.
- C) Push a second screw thru the remaining vacant hole in the aluminum bracket and then through the remaining vacant drill hole in the PVC tube.
- D) Attach lock nuts to each screw and tighten both securely

FIGURE 5

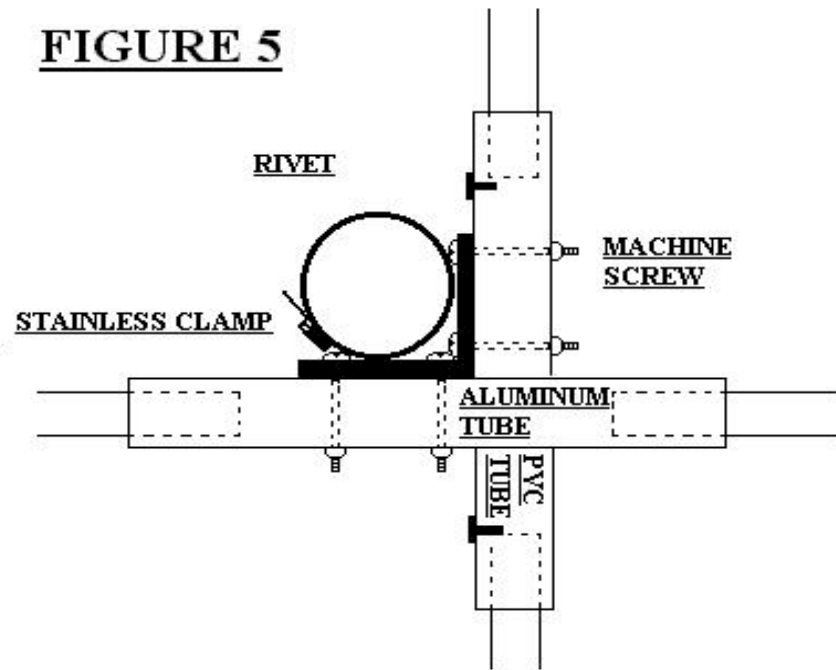

5.2 COUNTERPOISE ASSEMBLY see figure 6

- A) Attach the stainless clamp to the assembled Counterpoise bracket. Place the bracket against the Lower Section in between the two sets of screws at the base.
- B) Tighten the clamp securely
- C) It is recommended that the Counterpoise Hoop assembly, be deferred until the TITAN has been installed in it's final position. RAISING the antenna with the hoop installed is cumbersome and can damage the antenna. The following section is easier to complete after the antenna has been mounted. Check section 6.0 before continuing.

5.3 COUNTERPOISE HOOP

- A) Locate the 80" counterpoise rods. There are drill holes on both ends. Slide each rod into the Counterpoise bracket see figure 5 & 6. Make sure the rod with the yellow end cap slides into one side of the aluminum tube, not the PVC.
- B) Align the hole in the 80" rods with the hole in the counterpoise tubes. Insert a screw in both holes and tighten. This step is optional if you plan on frequently raising and lowering your antenna.
- C) Locate the 3 Counterpoise End Caps and the 35 foot copper Counterpoise Hoop with 1 ring terminal. The End Caps have a rivet in them.
- D) Each End Cap also has a thru drilled hole close to one end. Thread the end of the copper wire without the ring terminal thru these holes in the End Caps.

- H) Locate the Mid Section. It has 4 standoffs attached to one end. Slide the end with the 4 standoffs over the coax tail protruding from the Main Section center insulator.
- I) Align the holes on the insulator with the holes in the Mid Section. Place a screw and washer through the remaining ring terminal on the short yellow GAP lead coming out from the center insulator. Insert this screw in the hole closest to where the lead comes out of the center insulator. See figure 3. Insert the remaining 3 screws and tighten. Leave the standoffs as is, for the moment.
- J) Locate the Lower Section. It is a double wall and triple walled section for added strength. It has four long standoffs at one end.
- K) Slide the end with the standoffs over the coax tail and partially over the Mid Section. Align the 4 holes, insert 4 screws and tighten securely, remember to snug them all first. Do not attach the PL259 connector.

CHAPTER 4: TUNER ROD ASSEMBLY

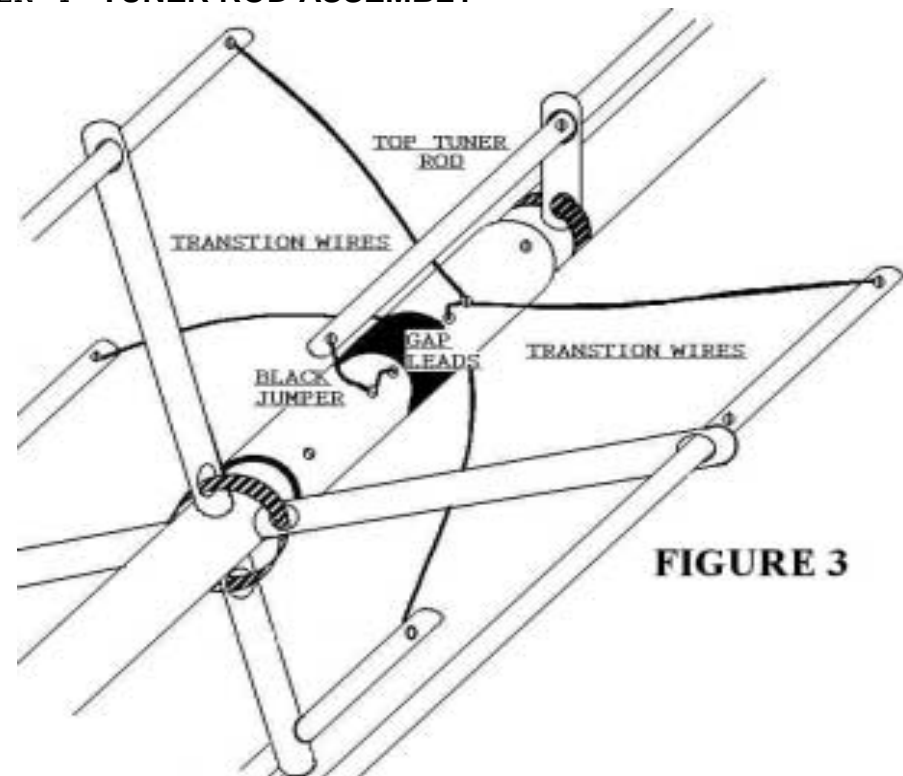

FIGURE 3

4.0 GENERAL

There are four 102" Mid tuner rods, two Lower tuner rods 30" and 60" and one 51" Top tuner rod. Two extensions complete the tuner rod package. The standoffs have been prepositioned at the factory for your convenience. When orienting these standoffs you should not have to move them along the mast, but simply loosen the clamp and lever them out, so they are perpendicular to the mast. If you should slightly shift their relative position along the mast don't despair. Slight movement is not critical.

IMPORTANT The length of the Counterpoise Hoop controls the center frequency on 40m. The longer the Counterpoise wire is, the shorter the Dacron rope is and the lower the resonant frequency will be. Likewise the shorter the length of the Counterpoise Hoop the higher the resonant frequency will be and the longer the Dacron rope will be. Adjust the Counterpoise Hoop and check the frequency with your VSWR meter on 40m. Adjust the length to suit your preference on 40m. Keep in mind that as you adjust the overall length of the Counterpoise hoop wire the loop created between the split bolt and the ring terminal on the Dacron should remain about 2"

5.4 POLE MOUNT ASSEMBLY-REFER TO FIGURE 7

- A) Locate the 3"x12" aluminum plate, the six U-bolts and twelve nuts.
- B) Insert the U-bolts into the plate as shown in figure 7
- C) Locate the six collar insulators. Place each under a U- bolt.
- D) Finger tighten the nuts on the ends of all the U-bolts.
- E) Using a 7/16" wrench tighten the U-bolts until the collars are just held in place.
- F) Take the assembled unit and slide it over the base of the antenna. They should slide freely. If not, they are overtightened and the U-bolts should be loosened.
- G) Continue to slide this unit up the base, until the collar on the first unit butts against the lower portion of the antenna. Tighten the nuts securely on the top unit.
- H) Make sure the nuts that hold the Lower section to the mount plate assembly are tight.
- I) Locate your 1 1/4" mast. Carefully slide your mast thru the 3 vacant insulating collars until your mast pipe is flush with the top of the mount plate assembly. Tighten all U-bolts with a 7/16" wrench.

5.5 COAX TAIL

- A) Bring the coax tail out through the exit hole in the side of the Lower Section. YES, it is important for the coax to exit through the hole in the side. Do not bring it straight out the bottom. Locate the PL259 connector with adapter. Attach the connector to the coax. See the ARRL Handbook if you are unsure of the procedure. In your final installation, make sure the connector does not touch your support mast.
- B) If properly connected, an ohm meter will read "open" when placed from centerpin to shell.

NOTE If your pipe is slightly oversized the PVC collars have been slit to allow for expansion. Operating without these insulators can affect performance.

PG13

6.1 GENERAL

A ham band transceiver and SWR meter are required for these tests. It is recommended that

CHAPTER 2: ANTENNA MOUNTING

2.0 General

The TITAN will accommodate a variety of mounting situations, some of which are described below. The preferred mount is a pole mount. It is simple and avoids the hazards of a roof top installation. Electing to roof mount the antenna is solely your decision and extreme caution should be exercised.

If you elect to elevate the antenna, always pre-test the antenna on the ground first. See Section 6.0 Locating a loose connection when the antenna is on top of a 40' mast is not easy!!

2.1 Pole Mounting

The TITAN is designed to be pole mounted. A mount plate assembly has been provided to attach the TITAN to a pole of your choice. It is recommended that you select a very heavy gauge steel pipe. The outside diameter of which should be 1.25". This pole may be attached to the side of a structure ie house or garage for additional support. If you elect to side mount, be certain your pole extends above the roof line to allow clearance for the Counterpoise hoop. Three foot clearance is typical.

If you elect to mount the TITAN on a pole in the yard, the pole should be mounted in an 18" diameter hole 3 feet deep or more and filled with concrete. It is far easier to erect the antenna with your support pole attached, rather than trying to lift the TITAN onto your support pipe. Thus your support pole should be such that it is removable from the concrete. To achieve this, procure a 3' length of 1.25" schedule 40 PVC. Make sure it will sleeve over your support pipe, if it is not large enough slit the pipe lengthwise and slide it over your pipe. Cover the slit with tape and place the PVC covered pipe in the 3' hole and fill with concrete. When the concrete has set remove your support pipe. You can now drop your support pipe into the hole you created by your PVC form.

2.2 TOWER MOUNTING

The TITAN may be mounted to a tower. Do not clamp directly to the tower. Use the Mount Plate Assembly to insulate the TITAN from the tower itself or the support. The TITAN must be placed at the top of the tower and not parallel with it. You may experience reduced bandwidth on a band if you tower mount the TITAN. This is generally a result of the tower exhibiting a resonance for that frequency.

2.3 TRIPOD/CHIMNEY MOUNT

The TITAN may be mounted in a tripod or to a chimney mount. Use the mount plate assembly to insulate the TITAN from the tripod or chimney mount.

CAUTION The TITAN and mount are in excess of 29' tall. Under no circumstances should a tripod or chimney mount exist without guy ropes. Guy the Antenna!

you use the minimum necessary power for the measurement. If possible, use an SWR bridge separate from that provided in your transceiver. Using a pencil, record your data in the space provided below.

6.2 FIRST OPERATION

A) If the TITAN has been assembled properly it will resonate close to the selected frequency on 75/80 meters. You should see a useable bandwidth in excess of 100 KHz under normal operation. Using minimal power, 10 watts or less;

Record the minimum VSWR on 75/80. _____
 2:1 VSWR Hi frequency _____
 2:1 VSWR Low frequency _____

B) Using minimal power, determine the resonate frequency on 40 meters.

Minimum VSWR _____
 2:1 Hi frequency _____
 2:1 Low frequency _____

C)30 meters is next. Freq. 10.100 _____
 10.125 _____
 10.150 _____

D)20 meters 14.00 _____
 14.175 _____
 14.350 _____

E) 17 meters 18.068 _____
 18.118 _____
 18.168 _____

F) 15 meters 21.00 _____
 21.225 _____
 21.450 _____

G) 12 meters 24.890 _____
 24.990 _____

H) 10 meters 28.00 _____
 28.50 _____
 29.00 _____

TITAN DX ANTENNA

Congratulations on your purchase of the GAP TITAN antenna. You soon will enjoy the ultimate in vertical antenna technology. Your GAP antenna has been designed and manufactured to provide superior performance, and a long trouble free life.

GAP technology produces highly efficient, wide bandwidth performance. As a result, no tuning is required in most amateur installations. This manual is organized to minimize the amount of time necessary to assemble and install your GAP vertical. It is recommended that you follow the instructions and use the figures as a guide.

Before beginning assembly, take a few minutes to read though the site selection chapter and to review the SAFETY notices. Please refer to Figure 1, the TITAN antenna, as you proceed with the assembly. Locate the parts, from the parts list in Figure 2. Call GAP direct if you find anything is missing.

The TITAN DX has been designed to operate efficiently on eight bands at 1500 watts PEP or less. The TITAN cannot be run continuously ie. Amtor, RTTY etc...at maximum power on 75/80m.

The use of an antenna tuner is not required. Tuners will not improve the performance of the TITAN, however they may permit a solid state transmitter to put out increased power. Operation of an antenna tuner when the VSWR is 2:1 or less is permitted. High power operation outside the specified bands using a tuner can damage the antenna.

CHAPTER 1: **SITE CONSIDERATIONS**
SAFETY, nearby structures, buildings, guying

CHAPTER 2: **ANTENNA MOUNTING**
 Pole, tower, or chimney

CHAPTER 3: **MAST ASSEMBLY**
 Space required, Mast Assembly, Step by Step

CHAPTER 4: **TUNER ROD ASSEMBLY**
 Top, Mid, Lower and Extensions

CHAPTER 5: **COUNTERPOISE AND MOUNT ASSEMBLY**

CHAPTER 6: **INITIAL TEST**
 First Operation...a place to record VSWR data

CHAPTER 7: **TIPS AND TROUBLESHOOTING**
READ THE SAFETY NOTICE ON PAGE 1 BEFORE CONTINUING

